

*Fiber laser
cutting machine*

ELECTRA FL

BEYOND YOUR EXPECTATIONS



Архангельск (8182)63-90-72
Астана (7172)727-132
Астрахань (8512)99-46-04
Барнаул (3852)73-04-60
Белгород (4722)40-23-64
Брянск (4832)59-03-52
Владивосток (423)249-28-31
Волгоград (844)278-03-48
Вологда (8172)26-41-59
Воронеж (473)204-51-73
Екатеринбург (343)384-55-89

Иваново (4932)77-34-06
Ижевск (3412)26-03-58
Казань (843)206-01-48
Калининград (4012)72-03-81
Калуга (4842)92-23-67
Кемерово (3842)65-04-62
Киров (8332)68-02-04
Краснодар (861)203-40-90
Красноярск (391)204-63-61
Курск (4712)77-13-04
Липецк (4742)52-20-81

Магнитогорск (3519)55-03-13
Москва (495)268-04-70
Мурманск (8152)59-64-93
Набережные Челны (8552)20-53-41
Нижний Новгород (831)429-08-12
Новокузнецк (3843)20-46-81
Новосибирск (383)227-86-73
Омск (3812)21-46-40
Орел (4862)44-53-42
Оренбург (3532)37-68-04
Пенза (8412)22-31-16

Пермь (342)205-81-47
Ростов-на-Дону (863)308-18-15
Рязань (4912)46-61-64
Самара (846)206-03-16
Санкт-Петербург (812)309-46-40
Саратов (845)249-38-78
Севастополь (8692)22-31-93
Симферополь (3652)67-13-56
Смоленск (4812)29-41-54
Сочи (862)225-72-31
Ставрополь (8652)20-65-13

Сургут (3462)77-98-35
Тверь (4822)63-31-35
Томск (3822)98-41-53
Тула (4872)74-02-29
Тюмень (3452)66-21-18
Ульяновск (8422)24-23-59
Уфа (347)229-48-12
Хабаровск (4212)92-98-04
Челябинск (351)202-03-61
Череповец (8202)49-02-64
Ярославль (4852)69-52-93

Киргизия (996)312-96-26-47 Казахстан (772)734-952-31 Таджикистан (992)427-82-92-69

<http://lvd.nt-rt.ru> || dvz@nt-rt.ru

ELECTRA FL

BEYOND YOUR EXPECTATIONS

With top level technology and high laser beam quality, the Electra fiber laser cuts a wide range of materials and thicknesses as fast as the thermal process allows without dynamic compromise.



HIGH-POWER FIBER LASER

A powerful IPG fiber laser source of 6 or 8 kW optimises machine performance, providing the flexibility to cut thick and thin materials at high processing speeds.



FRAME DESIGN

The extreme rigidity of the closed, welded steel frame construction and cast aluminium gantry is crucial in maintaining optimum part accuracy over the full cutting area.



ADVANCED CUTTING HEAD

Consistently high-quality surface finishes are achieved thanks to an advanced optical design featuring zoom focus, which allows adjustment of the focal diameter without operator intervention.





INTUITIVE CONTROL

The 19" touch screen control Touch-L allows fast and uncomplicated setup and conveniently displays cutting technology and nestings. Drawings can be imported directly into the control.



LINEAR DRIVE

The machine gantry features a linear drive motor to ensure extremely high dynamics and 2G acceleration while cutting.



AUTOMATIC SHUTTLE BED

Integrated spindle-driven shuttle tables ensure smooth movement and uninterrupted part processing. Shuttle table changeover is completed in just 30 seconds.

Electra's high cutting dynamics and rapid acceleration result in high part output.

HIGHLIGHTS

ADVANCED CUTTING HEAD

The Electra can cut a wide variety of materials and thicknesses delivering excellent quality at the highest possible speed without manual intervention. The cutting head with automatic focal height adjustment and zoom focus control can pierce 20 mm material in just two seconds.



HIGH POWER

Fiber laser systems have become the system of choice for most applications: they provide better beam quality and are extremely fast. Moreover, low maintenance costs, high efficiency, and small footprint are advantages of this technology.

High-power lasers have established a unique position within the fiber laser family. With their exceptional beam quality and high wall-plug efficiency of up to 40%, they are able to cut thicker materials at high speeds, increasing productivity and cut quality.



UNIQUE GANTRY

The cast aluminium gantry is lightweight, yet sturdy, not compromising on stiffness and durability. It minimises deformation caused by high acceleration.

Speed comparison nitrogen cutting

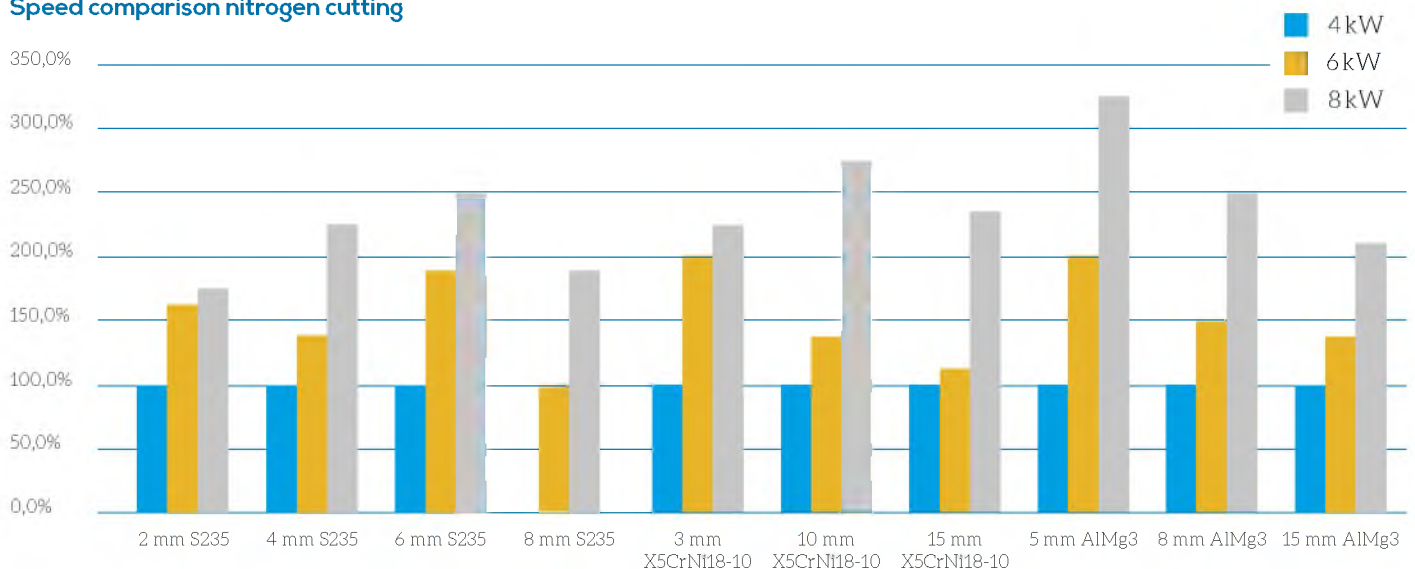

AUTOMATION

Modular automation options further increase the productivity and throughput of the Electra.

NOZZLE CHANGER

Requiring no operator intervention, the nozzle changer reduces downtime by quickly performing nozzle changes, including cleaning the nozzle and checking the nozzle alignment. This option brings greater autonomy, reduces piercing times and increases overall machine throughput.

Features:

- storage for 10 nozzles
- nozzle cleaning after a number of piercings
- automatic callibration of the capacitive height sensing
- camera that checks size and position and monitors the nozzle quality



COMPACT TOWER (CT-L)

The CT-L is a cost-effective tower for loading, unloading and storage of raw materials and finished parts. It is offered in three configurations: 4, 6 or 10 pallets. The system handles 3050 x 1525 mm sheets and material thicknesses up to 25 mm with a pallet storage capacity of 3000 kg. The CT-L unit facilitates unmanned production in a compact environment.



FLEXIBLE AUTOMATION (FA-L)

FA-L is an automatic load/unload system designed for flexibility and speed, an ideal complement to the high-speed Electra. It can unload a processed sheet and load the next sheet onto the table in just 40 seconds. The system handles 3050 x 1525 mm sheets and material thicknesses up to 20 mm with a pallet storage capacity of 3000 kg. Manual sheet handling is eliminated. FA-L is ideal for large volume applications with common material type, thickness and size.

Options:

- second loading pallet to increase flexibility and autonomy
- belts for scratch-free unloading
- connection to existing warehouse

The FA-L system can unload a processed sheet and load the next one in just 40 seconds.

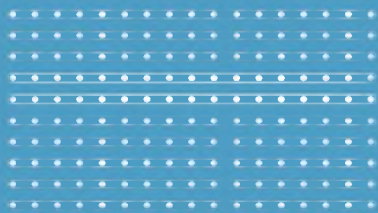

Key automation benefits

- maximise productivity and reliable production
- continuous production
- fully automatic loading and unloading during cutting
- easy to use, intuitive 19" touch screen control Touch-A
- high flexibility to process a variety of materials and thicknesses



ELECTRA FL-3015

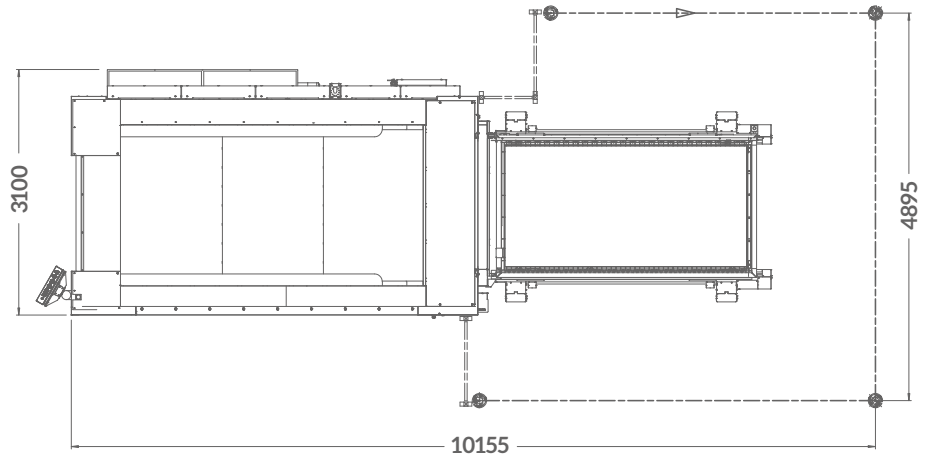

ELECTRA FL-3015 WITH COMPACT TOWER

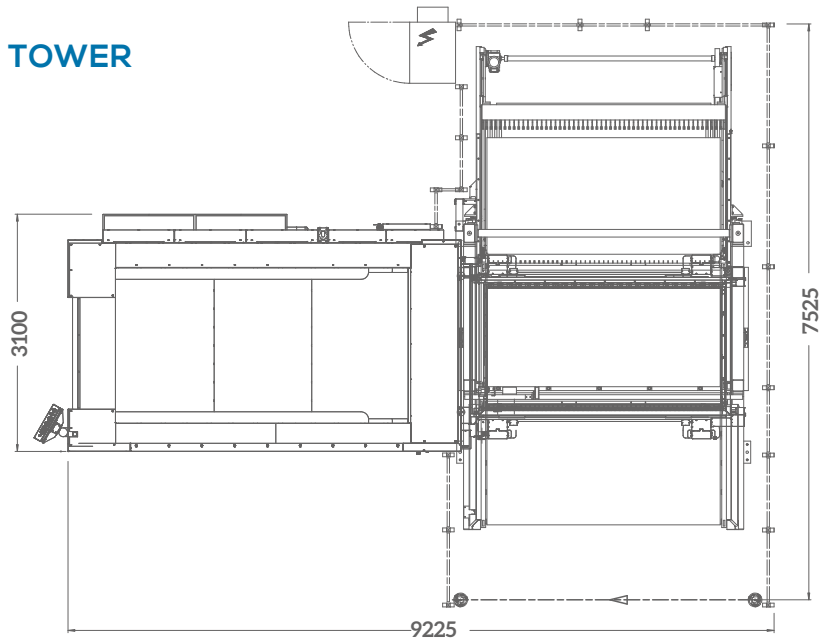

ELECTRA FL-3015 WITH FLEXIBLE AUTOMATION

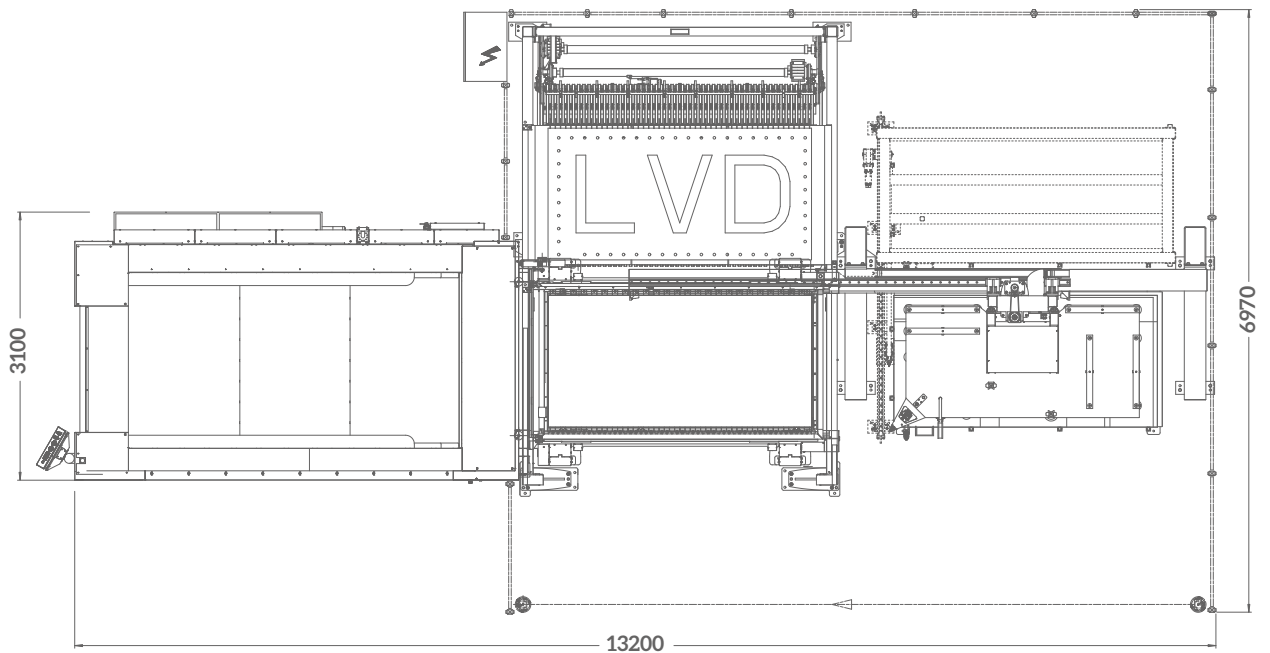

SPECIFICATIONS

ELECTRA FL-3015

MACHINE SPECIFICATIONS

Maximum sheet size	3050 x 1525 mm
X-axis travel	3080 mm
Y-axis travel	1555 mm
Z-axis travel	100 mm
Maximum sheet weight on table	900 kg
Table changeover time	30 sec.
Maximum positioning speed X-Y	170 m/min.
Repetitive accuracy	± 0.025 mm
Positioning accuracy*	± 0.050 mm

MACHINE DIMENSIONS (excluding filter and chiller)

Length x Width	10600 x 4900 mm
Height	2610 mm
Approximate weight	15000 kg

LASER SPECIFICATIONS

Type	IPG YLS	
Maximum cutting performance	6 kW	8 kW
Mild steel	25 mm	25 mm
Stainless steel	25 mm	25 mm
Aluminium	30 mm	30 mm
Copper	8 mm	12 mm
Brass	8 mm	10 mm

AUTOMATION OPTIONS

COMPACT TOWER (CT-L)

FLEXIBLE AUTOMATION (FA-L)

Maximum sheet dimensions	3050 x 1525 x 25 mm	3050 x 1525 x 20 mm
Minimum sheet dimensions	1000 x 1000 x 0,5 mm	1000 x 1000 x 0,5 mm
Maximum weight/pallet	3000 kg	3000 kg
Maximum height/pallet	240 mm	240 mm
Footprint (L x W)	9600 x 7600 mm	13600 x 6970 mm
Height of the system	-	3230 mm
CT-L 4 pallets	4200 mm	-
CT-L 6 pallets	5040 mm	-
CT-L 10 pallets	6720 mm	-

Specifications subject to change without prior notice.

* Achievable workpiece accuracy depends on the type of workpiece, pre-treatment and sheet size, as well as other variables.

According to VDI/DGQ 3441

Архангельск (8182)63-90-72
Астана (7172)727-132
Астрахань (8512)99-46-04
Барнаул (3852)73-04-60
Белгород (4722)40-23-64
Брянск (4832)59-03-52
Владивосток (423)249-28-31
Волгоград (844)278-03-48
Вологда (8172)26-41-59
Воронеж (473)204-51-73
Екатеринбург (343)384-55-89

Иваново (4932)77-34-06
Ижевск (3412)26-03-58
Казань (843)206-01-48
Калининград (4012)72-03-81
Калуга (4842)92-23-67
Кемерово (3842)65-04-62
Киров (8332)68-02-04
Краснодар (861)203-40-90
Красноярск (391)204-63-61
Курск (4712)77-13-04
Липецк (4742)52-20-81

Магнитогорск (3519)55-03-13
Москва (495)268-04-70
Мурманск (8152)59-64-93
Набережные Челны (8552)20-53-41
Нижний Новгород (831)429-08-12
Новокузнецк (3843)20-46-81
Новосибирск (383)227-86-73
Омск (3812)21-46-40
Орел (4862)44-53-42
Оренбург (3532)37-68-04
Пенза (8412)22-31-16

Пермь (342)205-81-47
Ростов-на-Дону (863)308-18-15
Рязань (4912)46-61-64
Самара (846)206-03-16
Санкт-Петербург (812)309-46-40
Саратов (845)249-38-78
Севастополь (8692)22-31-93
Симферополь (3652)67-13-56
Смоленск (4812)29-41-54
Сочи (862)225-72-31
Ставрополь (8652)20-65-13

Сургут (3462)77-98-35
Тверь (4822)63-31-35
Томск (3822)98-41-53
Тула (4872)74-02-29
Тюмень (3452)66-21-18
Ульяновск (8422)24-23-59
Уфа (347)229-48-12
Хабаровск (4212)92-98-04
Челябинск (351)202-03-61
Череповец (8202)49-02-64
Ярославль (4852)69-52-93

Киргизия (996)312-96-26-47 Казахстан (772)734-952-31 Таджикистан (992)427-82-92-69